



**SIGGRAPH2006**



# Streaming Media Portability

Brian Murray

Freescale Semiconductor

July 2006



**SIGGRAPH2006**

# Media Portability Problem

---

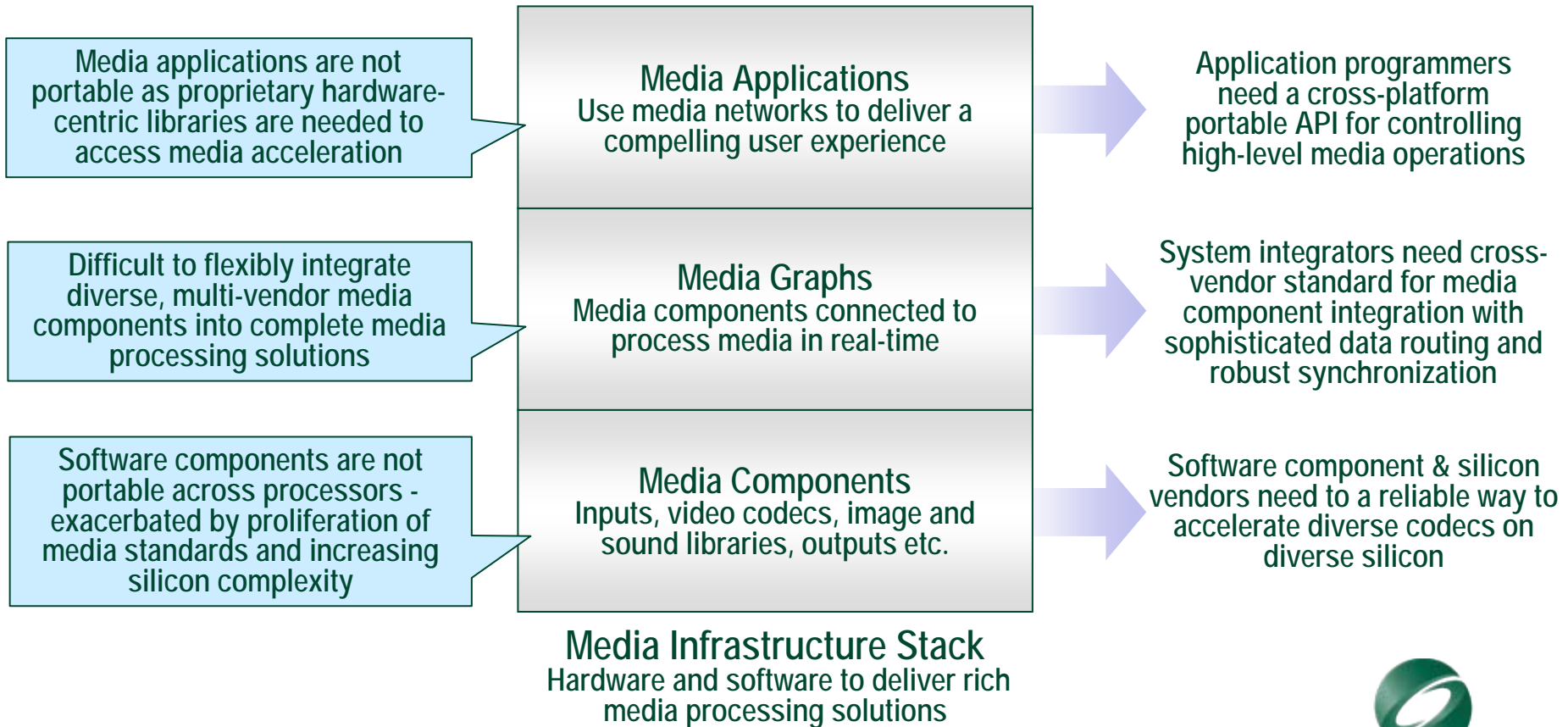

# OpenMAX - Three Layer Solution

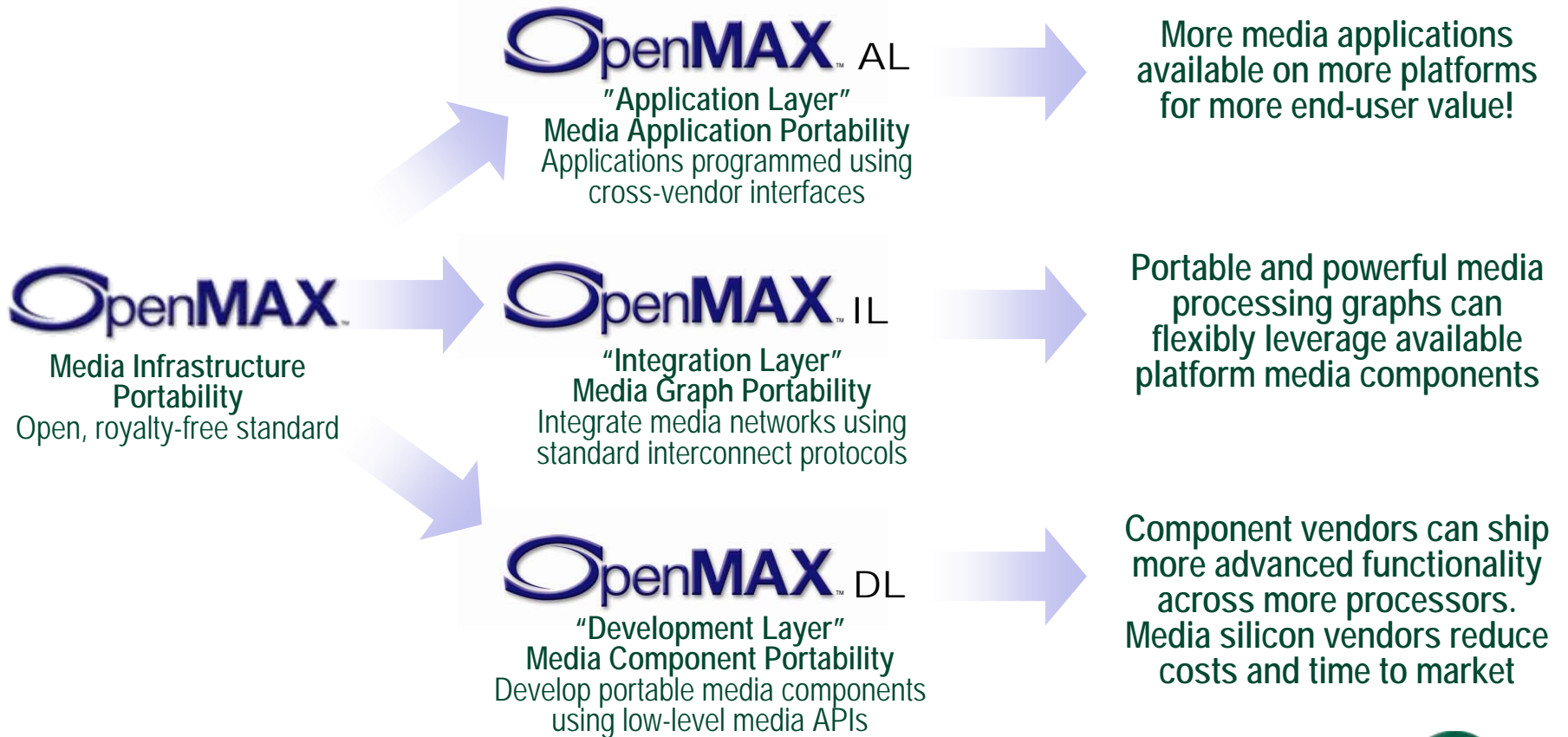

OpenMAX defines three holistically designed media open standards to provide complete media infrastructure portability



SIGGRAPH2006

# OpenMAX-based Media Stack

Media applications can be written portably, independent of the underlying media platform

Media components can be integrated into flexible media graphs for advanced streaming media processing

Media components can be written using primitives for portability across diverse parallel and serial silicon architectures

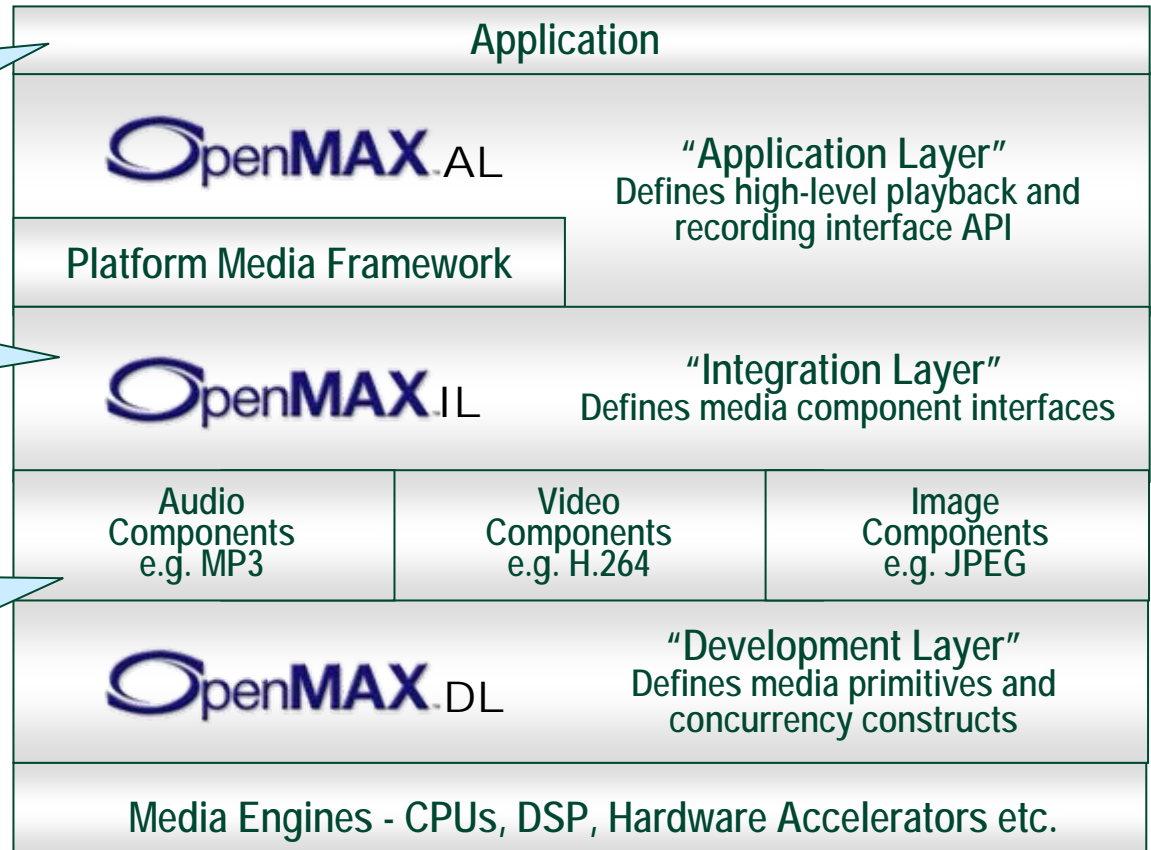

OpenMAX layers can be implemented together or independently from the other layers



# Complete Khronos Media Stack

The Khronos API family provides a complete ROYALTY-FREE, cross-platform media acceleration platform

Applications or middleware libraries (JSR 184 engines, Flash players, media players etc.)



3D  
Small footprint 3D for  
embedded systems



Vector 2D  
Low-level vector  
acceleration API

EGL

Abstraced Access to  
OS Resources  
Fast mixed mode 2D/3D  
rendering



SOUND  
Enhanced  
Audio  
Acceleration  
API



Playback and  
recording  
interfaces

Platform Media  
Frameworks



Component interfaces  
for codec integration

Image Libraries, Video Codecs,  
Sound Libraries



Accelerated media  
primitives for codec  
development

Media Engines – CPUs, DSP, Hardware Accelerators etc.

Khronos defines low-level, FOUNDATION-level APIs.  
"Close to the hardware" abstraction provides portability AND flexibility



# OpenMAX Working Group Structure

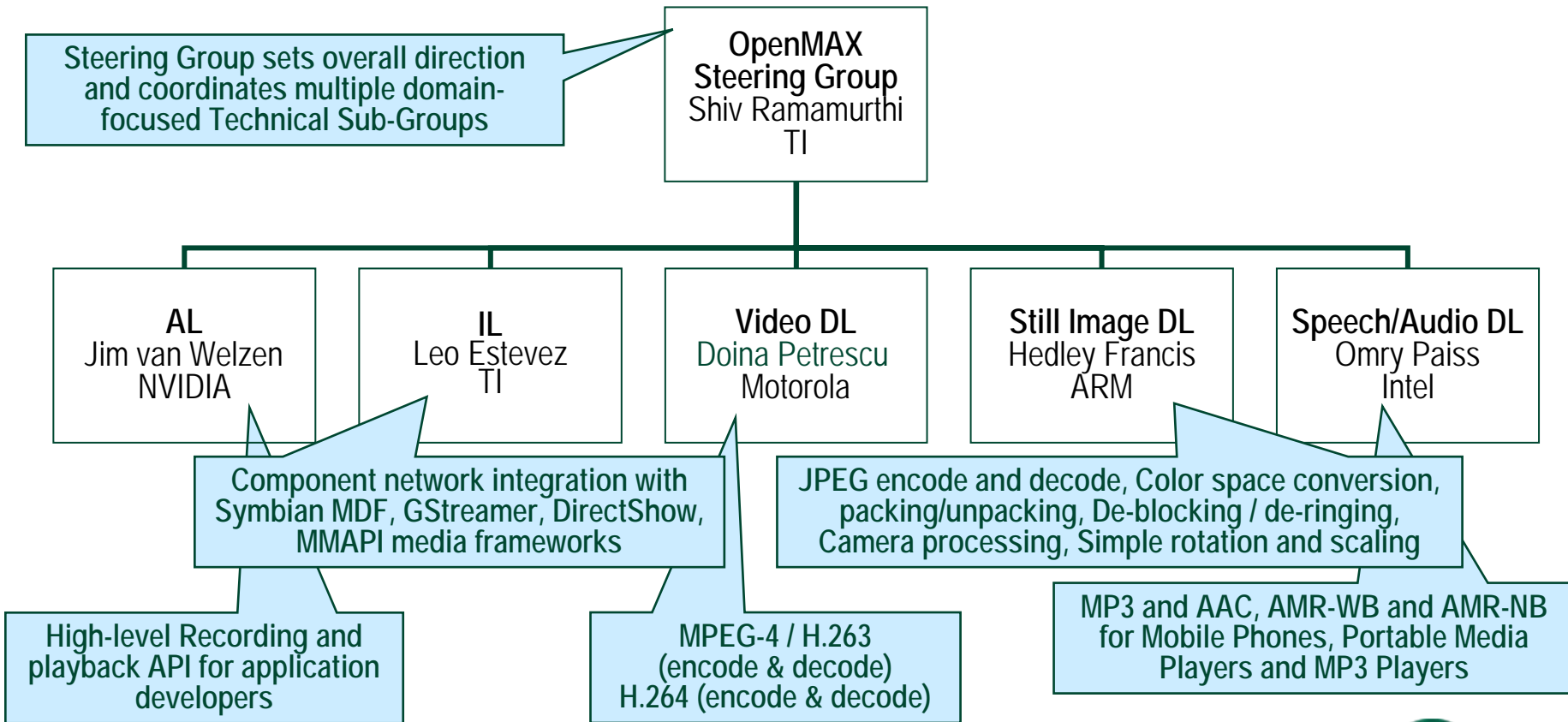

# OpenMAX Summary

---

- Three layer media infrastructure portability
- Strong industry consensus and participation
- Open and Royalty-free using Khronos IP framework

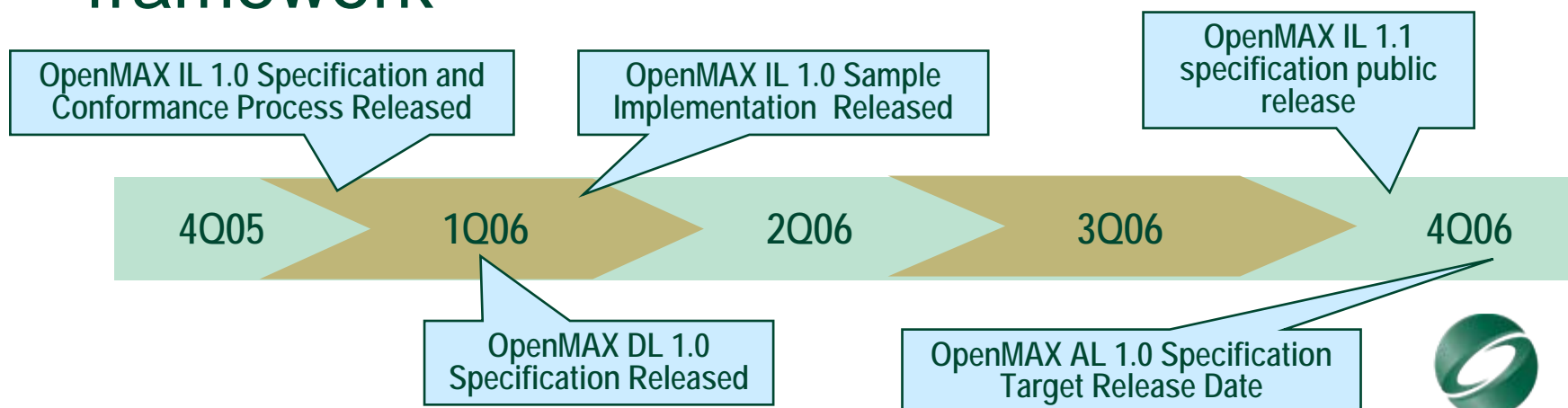

---

## Development Layer

**OpenMAX™**



**SIGGRAPH2006**

# OpenMAX DL – Low-Level Media API

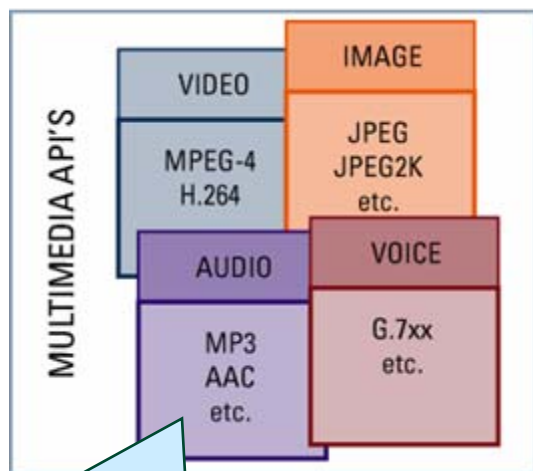

An increasing number of multimedia API codecs for video, audio, graphics and images

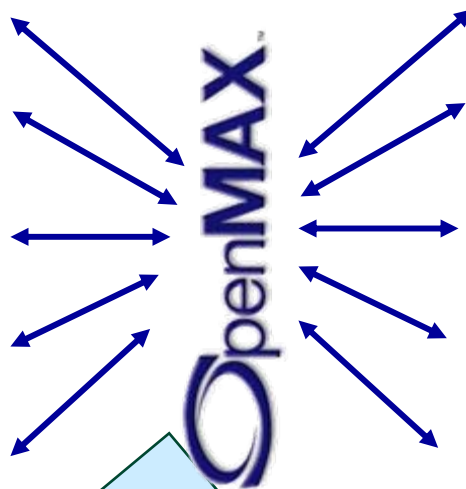

Silicon vendors supply optimized OpenMAX DL library for rapid porting of codecs across multiple accelerators

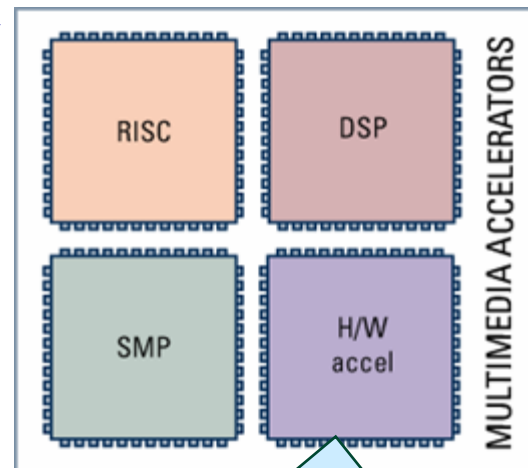

A wide range of media acceleration silicon using many diverse architectures



# OpenMAX DL – Low-Level Media API

---

- OpenMAX DL is a library of key static primitive functions
- Abstracts the ISA from the multimedia codec
  - Enables faster codec development time and faster porting of existing codecs
- Enables third party codec vendors to sell processor-agnostic codecs
  - Multi-core architectures (i.e. ARM + DSP) gain greater code reuse between cores



# OpenMAX DL Domains

---

- Video Domain
  - MPEG-4 SP/H.263 BL, H.264
- Image Processing Domain
  - Pixel packing/unpacking
  - De-blocking / de-ringing
  - CSC, Rotation, scaling, compositing, etc.
- Multimedia Audio Domain
  - MP3, AAC
- Image Codec Domain
  - JPEG
- Signal Processing Domain
  - FIR, IIR, FFT
  - Dot Product



# OpenMAX – Asynchronous DL (aDL)

---

- API to group or chain multiple DL primitives together into a single execution block
- Allows vendors to better leverage Specialized hardware and Co-processors.
- OpenMAX iDL
  - Achieves same effect as OpenMAX aDL using OpenMAX IL constructs



# OpenMAX DL Video Domain

---

- Basic video processing building blocks
- Example video primitive functions
  - 8x8 Add, Sub and 16X16 Add, Sub
  - 8x8 DCT+Q+Scan and 8x8 IDCT+Q+InvScan
  - MPEG-4 Variable Length Decode
- Merged functions for improved performance
  - Motion Estimation, Motion Compensation, Deblocking



# OpenMAX DL Image Domain

---

- Basic image processing building blocks
- Example image primitive functions
  - JPEG - encode and decode, 8x8 DCT and 8x8 IDCT, Quantization, Merged DCT & quantization functions, Huffman encoding and decoding
  - Image Processing - color space conversion and packing/unpacking, de-blocking / de-ringing filtering, Filtering, Moments, Block copy, rotation, mirroring and scaling



# OpenMAX DL Speech / Audio Domain

---

- Basic signal processing building blocks
- Example speech / audio primitive functions
  - Audio API - Unpacking of headers and bit-streams, Huffman decode, IMDCT and MDCT Polyphase filter, TNS and PNS processing
  - Signal Processing API - FFT and IFFT, FIR, IIR and Median filters, Dot product, Block exponent



---

## Integration Layer

**OpenMAX™**



**SIGGRAPH2006**

# OpenMAX IL - Integration Layer

---

- Defines component interfaces to construct portable media graphs
  - OpenMAX IL graphs are consistent across systems
- Abstracts system architecture
  - Components may be any combination of hardware and software



# OpenMAX IL - Integration Layer

---

- Reusable integration with major media frameworks
  - Symbian MDF, GStreamer, DirectShow, MMAPI, OpenML
- Extensible
  - API extensions can be used to expose non standard features with only minor tweaks
- Media graph use cases can be reused
  - Greater portability of API clients
  - Allows simpler debug between systems



# OpenMAX IL Example Graph

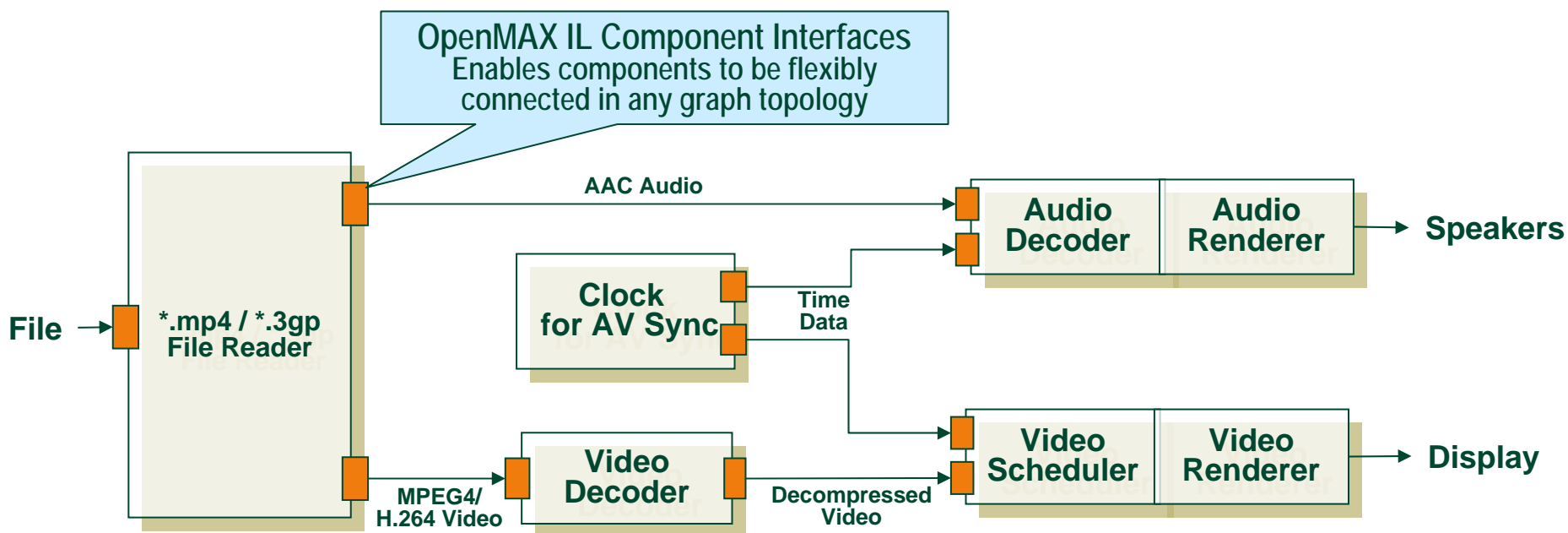

Example: MPEG-4 video synchronized with AAC audio decode



# OpenMAX IL Deliverables

---

- OpenMAX IL 1.0 specification
  - Publicly released January 2006
- Conformance Tests
  - Component based with two profiles
    - Base Profile - to test the component's basic operation
    - Interop Profile - to test the component's interoperable behavior with a test component



# OpenMAX IL Deliverables

---

- Implementation Whitepapers
  - Examples of how to implement Microsoft DirectShow, Symbian MMF, and GStreamer
- Linux sample implementation (coded by TI)
  - Video - H.263
  - Audio - Narrow Band AMR
  - Image - Baseline JPEG
- Bellagio OSS implementation (coded by ST)
  - ALSA and MP3 components (based on ffmepeg)
  - Available on Sourceforge



# OpenMAX Architecture & Features

---

- Objectives & Profiles
- System Architecture
- Component Architecture
- Component Registration
- Component States
- In-Context/Out-Context Behavior
- Buffer Allocation & Sharing
- Port Reconnection
- Buffer Queue Flush
- Buffer Marking
- Buffer Payload
- Buffer Flags
- Synchronization
- Rate Control
- Resource Management
- Future Features



# Tentative OpenMAX IL 1.1 Roadmap

- Standard Components
- OS Services
  - File I/O, Network I/O, Memory Management
- Security Hooks
- Power Management Hooks
- Resource Management Hooks

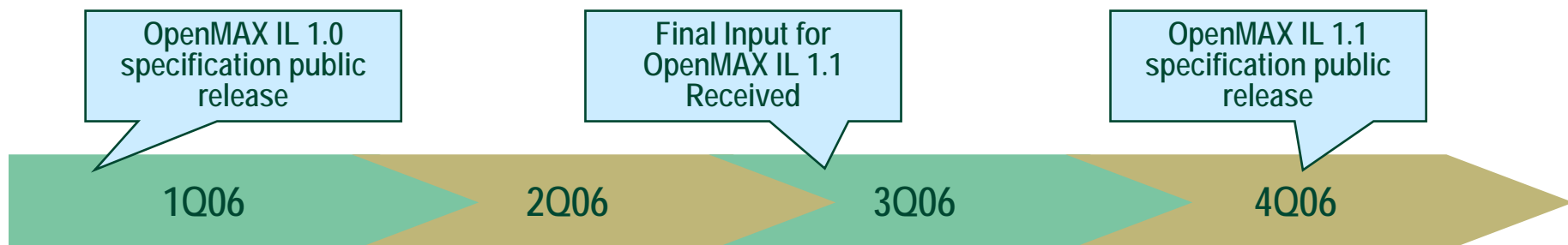

---

# Application Layer

**OpenMAX™**



**SIGGRAPH2006**

# OpenMAX AL - Application Level

---

- Enabling application developers to easily leverage OpenMax acceleration
  - A simple high-level interface for common multimedia playback and capture use cases
- Typical applications are found in:
  - Mobile Phones, Mobile Music/Video Players, PDAs, Digital still cameras, Digital Media Adapters, STBs, PCs, etc...



# OpenMAX AL 1.0 – Scope

---

- Standard use cases
  - Playback: play a video file, play a music file, display an image file
  - Recording: record a video file, record an audio file, capture an image file
- Operational controls
  - Playback: play, pause, stop, FF, RW
  - Recording: record, stop



# OpenMAX AL 1.0 – Scope

---

- Configuration control
  - Audio output: volume, channels, etc
  - Video output: video window composition, size, etc
- Metadata controls
  - Extract metadata from a playing stream
  - Insert metadata into a recording stream
- Supports Trans-API media within OpenKODE



# OpenMAX AL - Milestones

---

- Currently building API architecture
- Still time for new members to participate
- Q4 2006 release

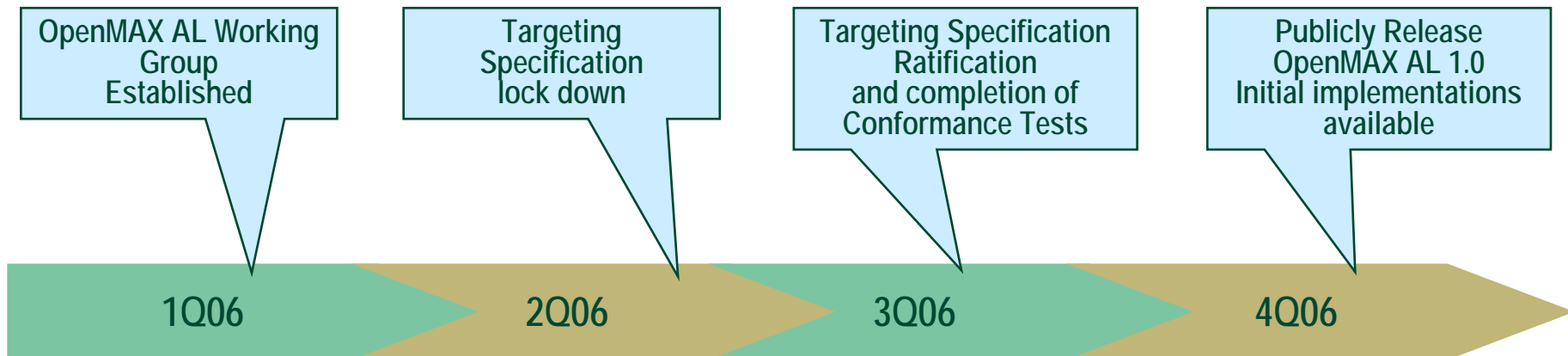

---

**Questions?**

**OpenMAX™**



**SIGGRAPH2006**



**SIGGRAPH2006**